

# FLATWORK FOLDER

**YOUR BEST MOVE FRB**

**GIRBAU**

LAUNDRY EQUIPMENT



# FRB FLATWORK FOLDER

## AN OPEN WINDOW TO YOUR LINEN



FRB 2V-4V UX3P

### EFFICIENCY AND TOUGHNESS FOR A PERFECT FOLDING

#### **+** VISIBILITY AND INTERNAL LIGHTING

The design of our FR folders gives you simple control and perfect monitoring of how pieces are folded. Optional internal lighting. Direct access to key points for practical, and efficient maintenance.

#### **+** CONTROL

Total control of production. Equipped with a touch screen for direct access, with graphical menus to make it as easy as possible for operators to understand and control. Total communication with Girbau flatwork ironers and feeders. Remote access and control with Ghelp.

#### **+** NEW APB STACKER

Simple and robust design with smooth movement of flaps. Output to the left or right side.

#### **+** VERSATILITY

The FRB folder can make two or three primary folds and three cross folds, adapting to production needs.

#### **MOVING TABLE**

This option improves the folding of large items.



#### **FITTED TRAY + COUNTER FOR SMALL ITEMS (4 LANES)**

Optional accessory fitted at the back of the folder. Suitable for collecting small items like napkins, pillowcases or cloths. Can also be supplied with screens for counting.





# GIRBAU

## 2-4 FEEDING LANES

Flexible operation depending on the dimensions of the linen to be folded.

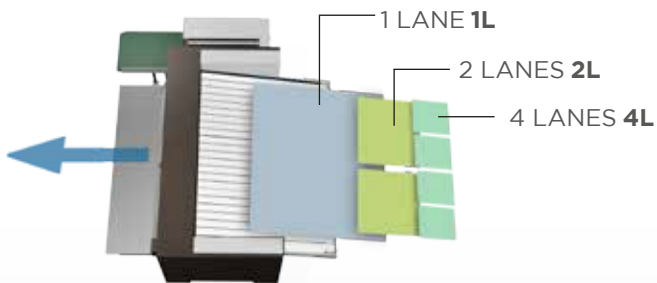

## 3 CROSS FOLDS UX3P

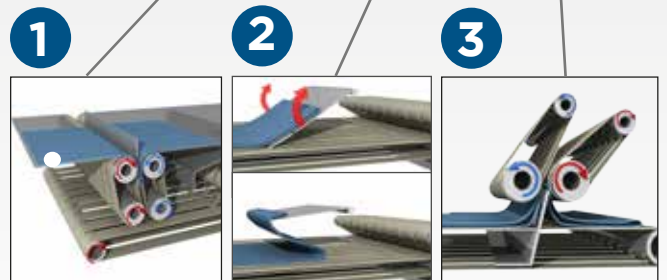

Makes 2 or 3 cross folds as standard working on 1 lane. Its concept maximises fold quality by adapting to any type of linen. Working in 2 or 4 lanes, the exit is on the table.

## PRIMARY FOLDING UX

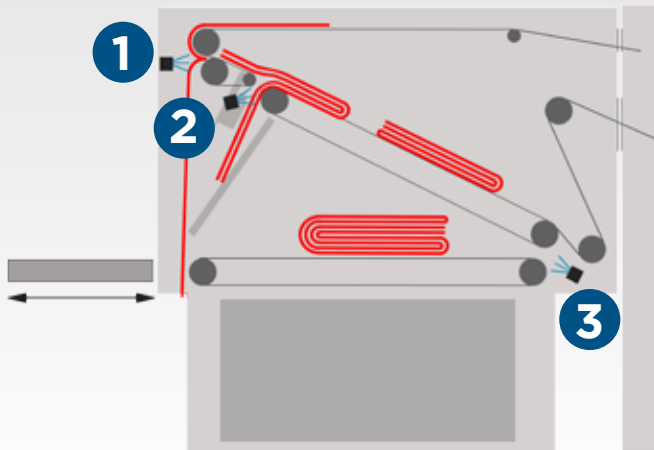

Two primary folds as standard and a third primary fold (optional) for large items.

# FRB FOLDER



P00380 04/16

Model	FRB		
<b>Electricity</b>	Voltage and frequency (standard)		380-400V - 50Hz
	Power cable section	mm <sup>2</sup>	3x2,5
	Installed power	KVA	2.8 to 3.2
<b>Compressed Air</b>	Maximum feeding pressure	bar	10
	Minimum pressure	bar	6
	Feed pipe section		15x21
	Average consumption per 100 sheets		5Nm <sup>3</sup> /100p 835 litres/100p at 6bar
<b>Others</b>	Noise level	dbA	76
	Weight	kg / (lbs)	1700 to 1900 / (3747 to 4188)
	Stacker weight	kg / (lbs)	275 (606) (single) - 550 (1212) (double)
	Load on feet	N/cm <sup>2</sup>	54 to 60
	Speed	m/min	10 a 50 (32 to 164)

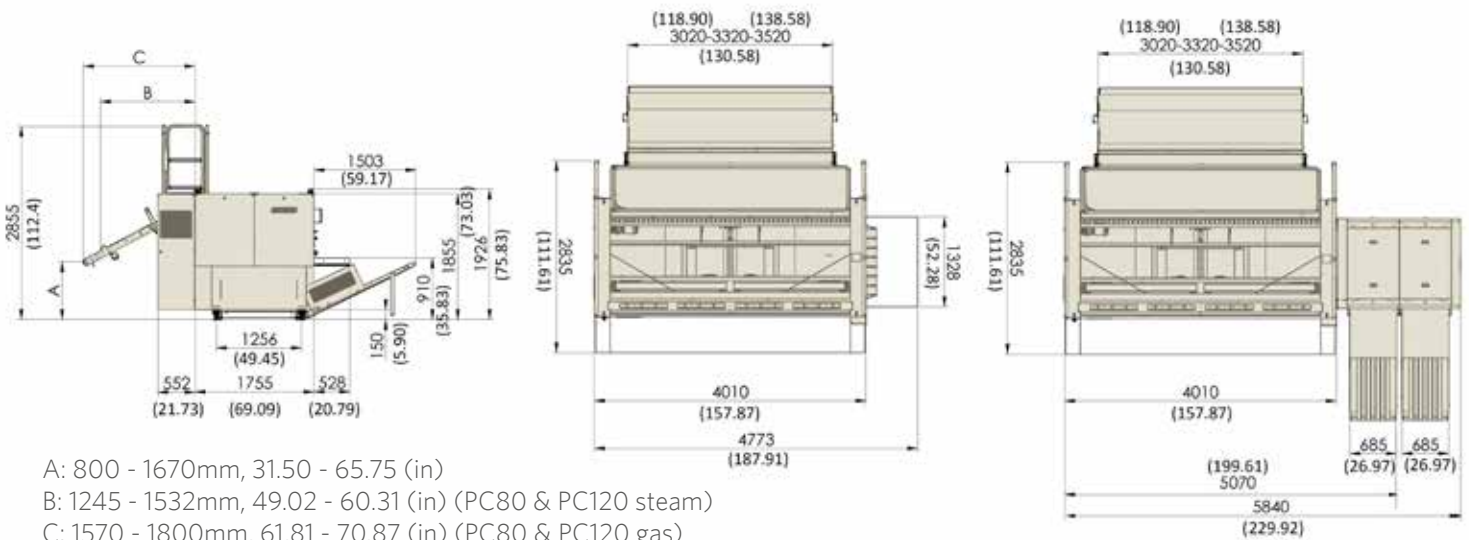

A: 800 - 1670mm, 31.50 - 65.75 (in)  
 B: 1245 - 1532mm, 49.02 - 60.31 (in) (PC80 & PC120 steam)  
 C: 1570 - 1800mm, 61,81 - 70.87 (in) (PC80 & PC120 gas)

GIRBAU S.A. reserves the right to change specifications without notice

## BRANCHES

Argentina - Buenos Aires - Tel. +54-1 149017600 - girbauargentina@girbau.com.ar  
 Australia - Sydney - Tel. +61 2 96755860 - sales@girbau.com.au  
 Brazil - Sao Paulo - Tel. +55 11-29820446 - girbaudobrasil@girbau.com.br  
 Cancún (Mex.) - Tel. (+52) 998 884 0517 - serviciotecnico@girbau.mx  
 China - Shenzhen & Hong Kong - Tel. +86-755-8211 1330 - info@girbau.com.cn  
 Cuba - La Habana - Tel. (+53-7) 8662071 al 73 - girbau@girbau.co.cu  
 Dominican Rep. - Punta Cana - Tel. +1 809-959-0615 - info@girbau.do  
 France - Roissy (Paris) - Tel. +33 1-49388585 - info@girbau.fr  
 Germany - Ratingen - Tel. +49 2102 9934619 - girbau@girbau.de  
 Italy - Marcon (VE) - Tel. +39 0418654330 - info@girbau.it  
 Portugal - Porto - Tel. +351 22 3758909 - vendasportugal@girbau.pt  
 U.A.E. - Dubai - Tel. +971 4-8839951 - sales@girbau.ae  
 U.K. - Hitchin - Tel. +44(0)-1462 427780 - info@girbau.co.uk  
 U.S.A. - Oshkosh, WI & Los Angeles, Ca - Tel. +(1)920) 2318222 - info@continentalgirbau.com

## HEADQUARTERS

GIRBAU, S.A. Ctra de Manlleu, km. 1 - 08500 Vic (Barcelona) Spain - www.girbau.com  
 Tel. (+34) 93 886 2219 - Fax (+34) 93 886 0785 - sales@girbau.es

